

# CASSIOPEIA

## Desktop Sit-Stand Retrofit

Models: DSS-27 and DSS-36

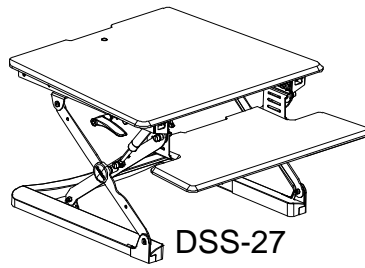

DSS-27

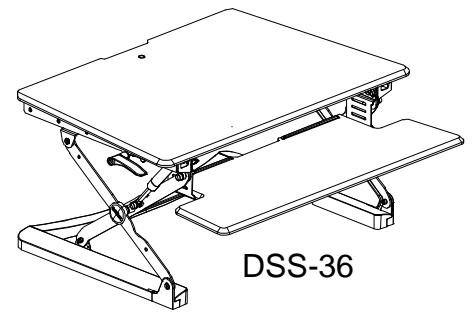

DSS-36

### ▲ CAUTION

Please read all instructions before using this product.  
Retain this manual for future reference.  
The specifications of the product may vary slightly from the illustrations.

### Package Contents

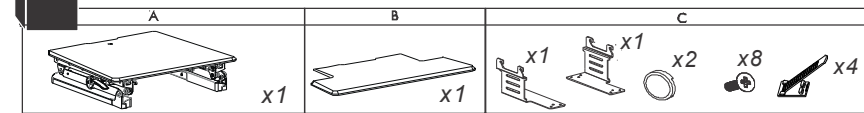

### Tools Required

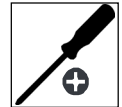

### Technical Data

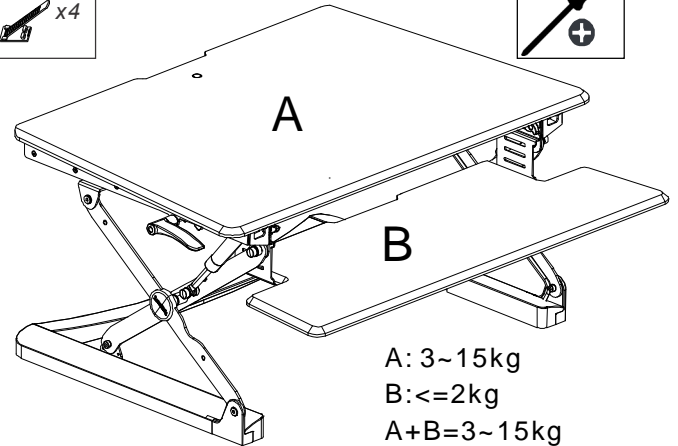
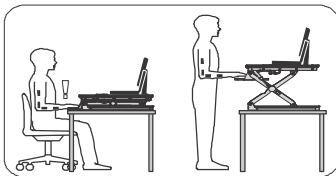

### ▲ CAUTION

Exceeding maximum weight loads will void warranty.

### Assembly Step 1

Carefully open carton and remove the CASSIOPEIA from the packing materials.

Carefully place the sit-stand unit on the desk or table surface.

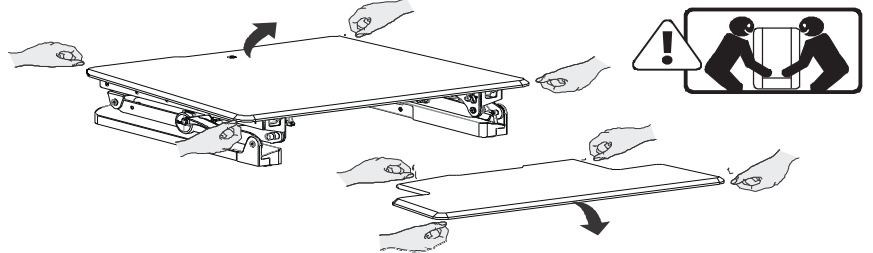

### ▲ CAUTION

Use appropriate safe lifting techniques when removing the CASSIOPEIA from the packaging materials.

### Assembly Step 2

a. Snap the decorative safety cover onto the lifting arms.

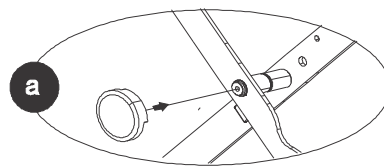

b. Attach the keyboard tray brackets to the keyboard tray using the 8 screws provided.

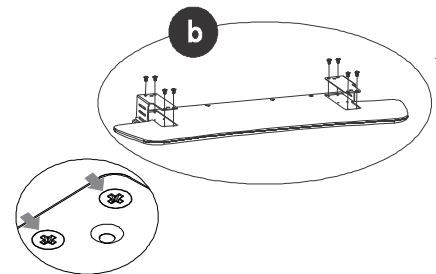

c. Suspend the keyboard brackets from the knob assembly below the front of the work surface.

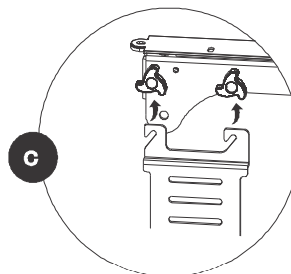

d. Tighten keyboard bracket knobs to secure the keyboard tray in place.

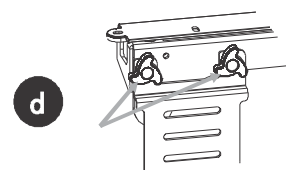

### ▲ CAUTION

DO NOT overtighten screws.  
For best results the heads of the screws should be just flush with the counterbored hole in the bracket.

### Assembly Step 3

To raise or lower the CASSIOPEIA, simultaneously squeeze the release paddles on both sides. With the paddles squeezed, raise or lower the work surface to the desired height and then release the paddles to engage the locking mechanism. The unit will then lock into place at the next highest position.

NOTE: Both release paddles must be fully engaged at the same time to avoid catching or uneven adjustment.

#### ▲ CAUTION

For safety please ensure that no hands or equipment are near the scissor lift mechanism when the height of the unit is being adjusted.

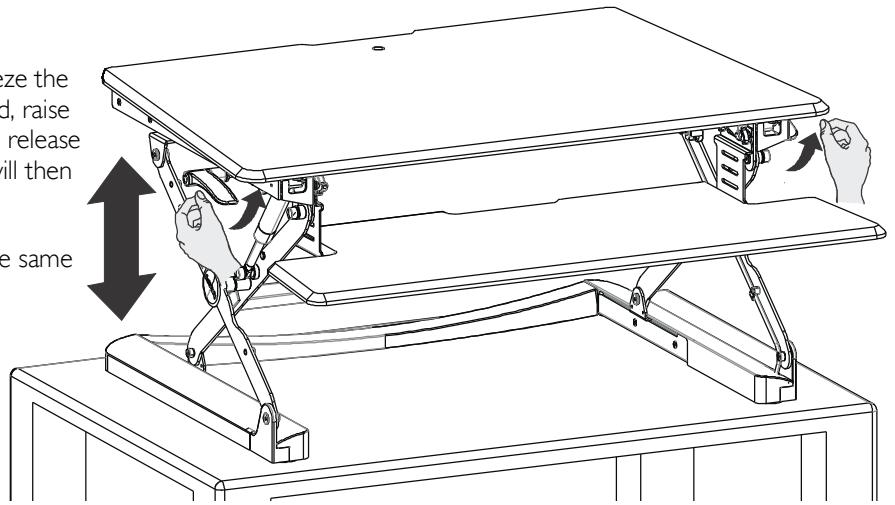

### Assembly Step 4

Raise the CASSIOPEIA to the maximum height before placing equipment on the work surface.

If a monitor arm (optional) is to be used to provide greater elevation it should be attached at this point and the monitor(s) secured in place.

Position keyboard, mouse, and monitor(s) so that they are fully supported by the workstation surfaces.

Use the included Cable Clips or optional cable routing guides to safely route cabling in order to avoid potential damage. Ensure that cables have sufficient length to permit full and easy adjustment throughout the entire height range.

#### ▲ CAUTION

Please ensure that all devices are fully supported on the appropriate surfaces. Do not exceed the recommended weight bearing loads. Doing so will void warranty.

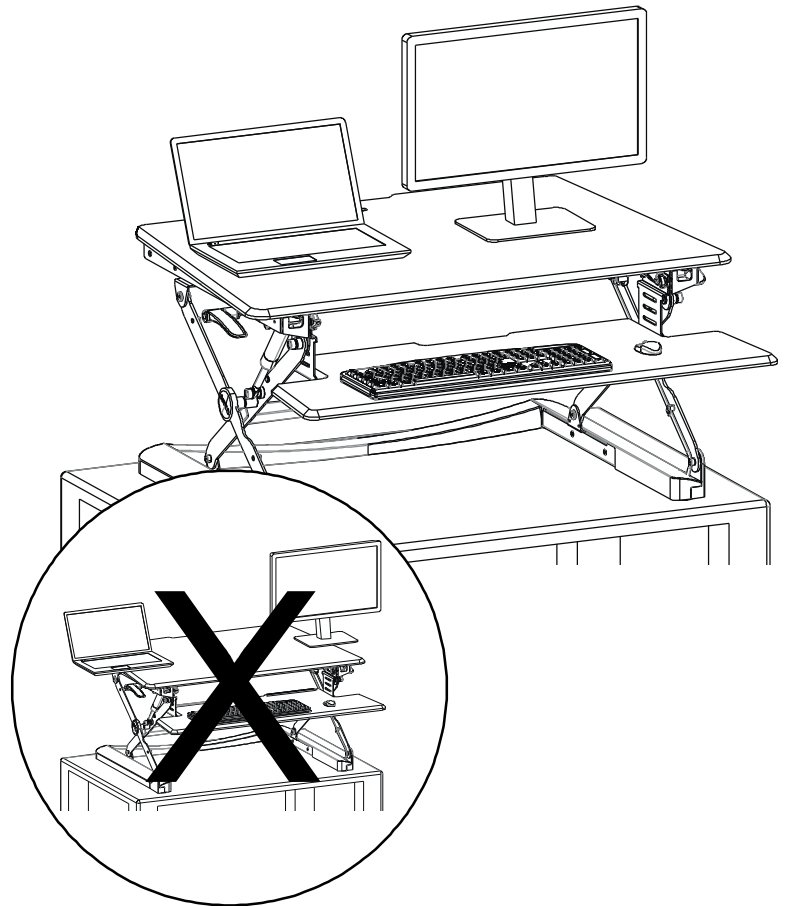

#### ▲ CAUTION

Prior to removing equipment from the CASSIOPEIA the work surface should be raised to the maximum elevation.

#### ▲ CAUTION

When moving the CASSIOPEIA ensure that the unit is fully locked before removing from the desk. Appropriate safety precautions and lifting protocols should be adhered to.

### WARRANTY

CASSIOPEIA Desktop Sit-Stand Retrofit units come with a 2 year limited warranty against defects in material and workmanship under normal use and service.